

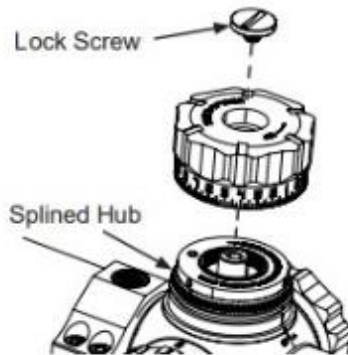

6-24x50 Zero Stop Instructions

Zero Stop Instructions:

1. Before you start shooting to Zero in your scope. Loosen the Lock Screw on the elevation turret to make it easier for the next steps. A cartridge case or coin will work.
2. Zero in your scope.
3. Once you have your Point of Impact (POI) where you want, remove the Lock Screw and pull off the dial to see the Splined Hub and Zero Stop Dial "washer". Do this slowly not to turn the dial.



4. Turn the Zero Stop Dial clockwise until it stops.
5. Use the 1/32 in hex wrench to turn the three zero stop dial set screws clockwise until tight.
6. Align the '0' on the elevation dial with zero indicator line on the elevation turret.
7. Use a cartridge case or a coin to turn the elevation dial screw clockwise to tighten back down.

